

# PRODUCT FACT SHEET

## FLUID PENDANT LAMP FURNITURE / LIGHTING / ACCESSORIES

**Claesson Koivisto Rune on the design** "We wanted to give the lamp a form with a certain softness, towards a more natural language and further removed from pure geometry. Fascinated by the way that surface tension governs the curvature of a resting water droplet, we have tried to capture it's essence. The subtle irregularity of FLUID means that their silhouette gently changes depending upon the viewing angle. It also brings a greater light intensity to the lamps' underside - just where you need it."

PROCESS	The Fluid lamp shade is made out of mouth blown glass, which is frosted silky mat. The edge on top of the lamp is grinded and polished.
DESIGNED BY / YEAR OF DESIGN	Claesson Koivisto Rune / 2011 & 2013
TYPE	Pendant light
LAMP DESCRIPTION	Fluid pendant lamp is a modern pendant with personality and ambience. Place the lamp alone over a table, or mix small and large Fluid lamps. Arrange in rows or clusters to create a cosy atmosphere & beautiful light.
ENVIRONMENT	Indoor
MATERIAL	White silk mat opal glass, Lid in Nylon66 with Fibre glass.
COLOUR / REF. CODE	Silk mat opal glass
VOLTAGE (V)	Large: 220V-240V, 50Hz, E27 1x Max 60W or 1 x 13W, CFL, Class II  Small: 220V-240V, 50 Hz, G9 1x Max 40W, Class II, IP20. Bulb type G. 1600 - 2000 hours Energy class C.
DIMENSION	Small Ø: 23 H: 14,3 Large Ø: 42 H: 27
CANOPY	Yes
BULB INCLUDED	Large: No Small: Yes
CORD LENGTH (MM)	3500 mm - Longer cord is available for projects, contact <a href="mailto:contractsales@muuto.com">contractsales@muuto.com</a>
CLEANING INSTRUCTIONS	Clean with soft dry cloth only. Always switch off the electricity supply before cleaning.
ABOUT THE DESIGNER	Claesson Koivisto Rune is one of Swedens most prominent design studios and the three designers have among many international awards been awarded the annual Swedish design award eight times.

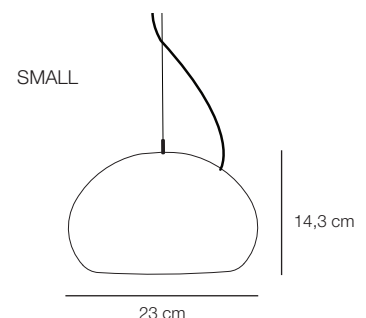
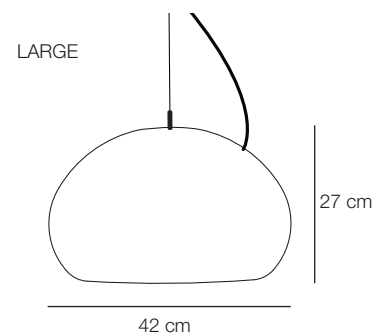
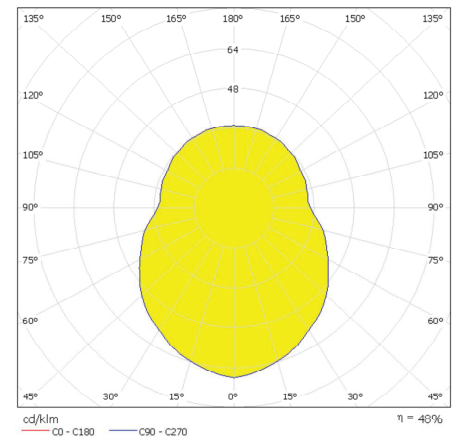

CERTIFICATIONS



**MUUTO**  
New Nordic